

SES

Stainless Single-Jet Meter Instructions



General Information

General Information Page 3
Features Page 3
Specifications Page 4
Dimensions Page 4
Flow Range..... Page 4
Pressure Drop Curve..... Page 5

Installation & Connections

Piping Requirements Page 5
K-Factor Page 5
Connections to Non-Seametrics Control Devices Page 5

Repair

Rotor Replacement Page 6
Sensor Replacement..... Page 6
Parts List..... Page 7

Troubleshooting

Problem Back
Probably Causes..... Back
Things to Try..... Back

The **SES** single-jet meter provides accurate, wide range flow metering in an extremely rugged stainless steel package. Single-jet simplicity combined with high quality jewel bearings results in long life and relatively high tolerance for problem fluids. Typical applications are chemical batching, proportional chemical injection, fertilizer injection, proportioning of spray chemicals, and general flow rate monitoring.

The sensor is easily replaced from outside the meter, and is compatible with most of the Seametrics indicators and transmitters, as well as most controls and PLC's that accept DC inputs. The standard rotor is PVDF (Kynar®) and the shaft is a special nickel-bonded tungsten carbide.

The optional ceramic shaft increases resistance to some concentrated chemicals. The standard O-ring is Teflon®-coated Viton®.

Features

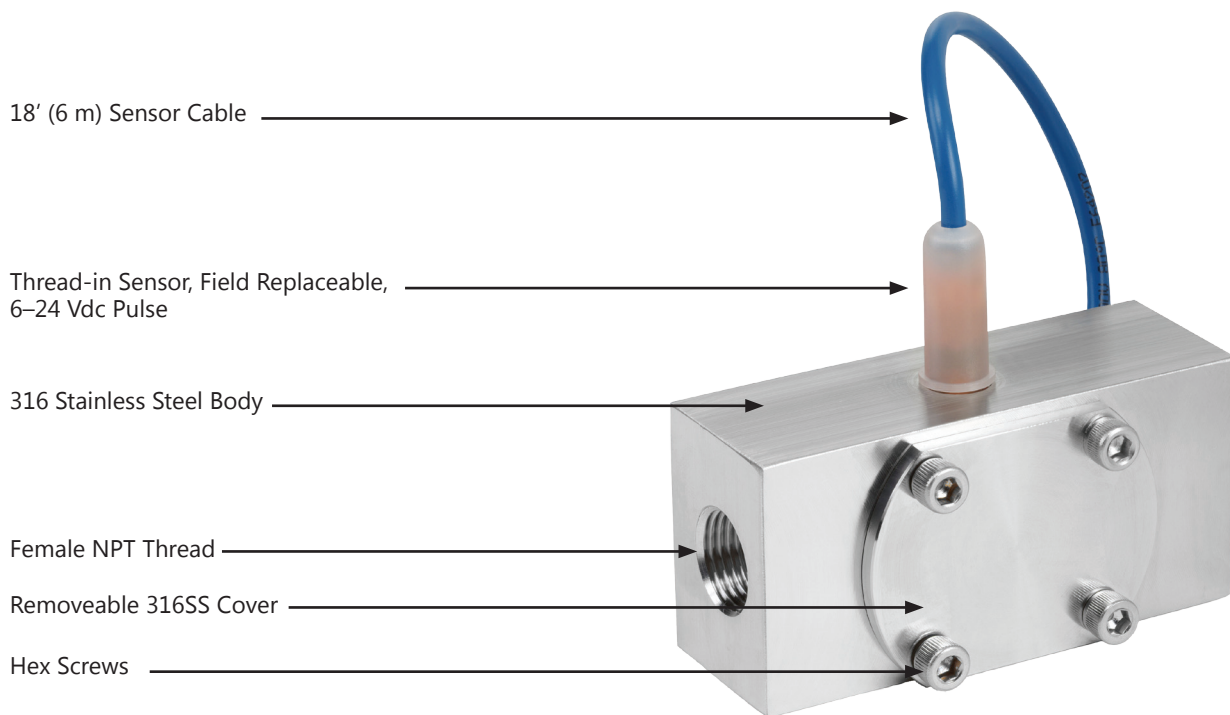

Internal

- Jewel Bearings—Ruby Ring and Ball
- Kynar®/Tungsten Carbide Rotor Assembly (*Kynar®/Ceramic or Kynar®/Silicon Carbide optional*)
- Teflon®-coated Viton® O-ring (*Viton® or EPDM optional*)



Field Replacement of Sensor

Specifications*

Connection Ports	1/2", 3/4", 1" —Female NPT thread	
Sensor Cable	18 ft (6 m) standard—maximum cable run 2000 ft (607 m)	
Materials	Body	316 stainless steel
	Rotor	PVDF (Kynar®)—2 magnet (6 magnet high resolution optional)
	Shaft	Nickel-bonded tungsten carbide (ceramic or silicon carbide optional)
	O-Ring	Teflon®-coated Viton® (Viton® or EDPM optional)
	Bearings	Ruby ring and ball
	Cover	316 stainless steel
Maximum Temperature	200° F (93° C)	
Maximum Pressure	500 psi (35 bar)	
Accuracy	±1% of full scale	
Power	Standard	6–36 Vdc, < 2 mA
	Micropower	3.1–16 Vdc, 60 µA @ 3.6 Vdc (for FT450 and DL76 only)
Outputs	Current sinking pulse, 6–24 Vdc	

* Specifications subject to change. Please consult our website for current data (seametrics.com)
 Kynar is a registered trademark of Arkema, Inc., Teflon and Viton are registered trademarks for DuPont Corporation

Dimensions

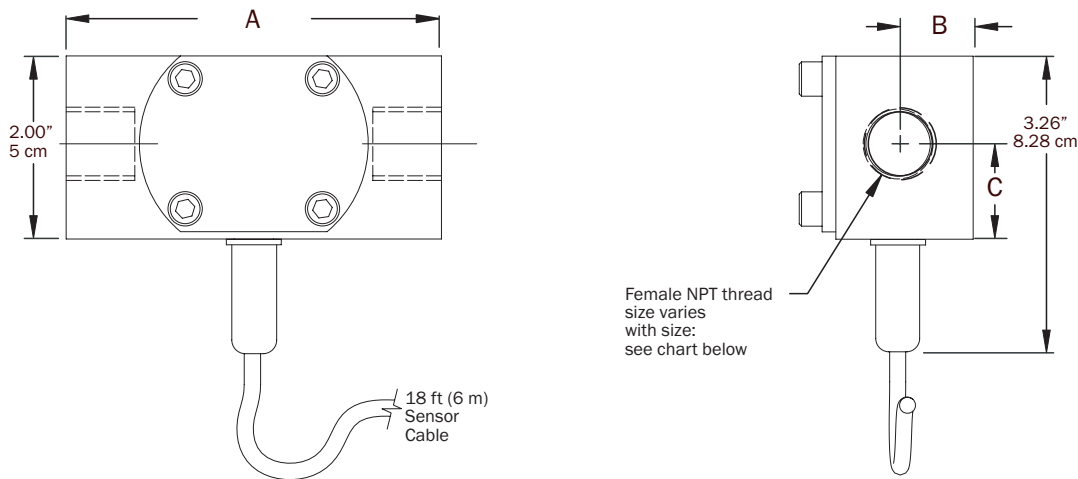

Model	NPT Thread Size	A	B	C
-050	1/2 inch	4.10	0.82	1.04
-075	3/4 inch	4.10	0.82	1.04
-100	1 inch	5.00	0.75	1.00

Flow Range

Model #	K-Factor* (pulses/gal)	Gal/Min	Liter/Min
-050	535	0.1–10	0.38–38
-075	390	0.2–15	0.75–57
-100	220	0.5–25	1.9–95

*Nominal K-factors (based on averages) for standard 2-magnet version. High resolution (6-magnet) K-factors are approximately tripled.

Pressure Drop Curves

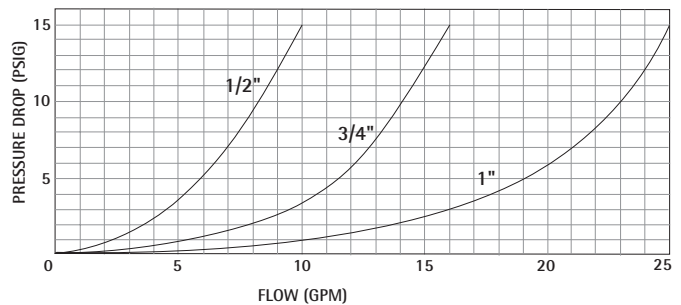

INSTALLATION

Piping Requirements

Standard fittings are female NPT. Straight pipe of at least five diameters upstream of the meter is recommended. Vertical or horizontal installations are acceptable.



WARNING:
This meter has low-friction bearings. DO NOT AT ANY TIME test operation of the meter with compressed air. Doing so will subject it to rotational speeds many times those for which it was designed, and will certainly damage the rotor, shaft, and/or bearings.

K-Factor

The meter is factory calibrated. The K-factor is found on the label on the meter body and must be input into the control/display for accurate reading.

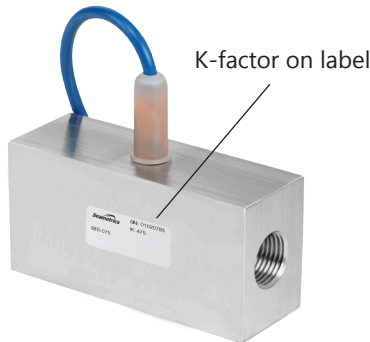

CONNECTIONS

Connecting to Non-Seametrics Control Devices

It is often desirable to connect an SES flow sensor to a PLC or industrial computer board, and the sensors are well suited for this. Typically it can be connected directly, or with a single resistor added. The pickup sensors are current sinking (NPN) GMR devices that require 6–36 Volts DC and 2 mA current. They can connect directly to a PLC or computer board if:

1. The sensor power supply on the PLC is 6–36 Vdc (24 Vdc is typical).
2. The sensor power supply can provide at least 2 mA (100 mA is typical).
3. The sensor input on the PLC can accept a current sinking device.
4. The PLC frequency response > flow meter output frequency.

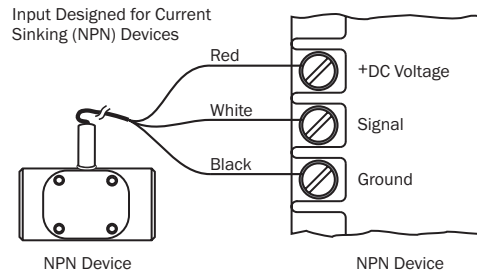

Input designed for current sinking devices (NPN)

If the PLC input only accepts current sourcing devices, a pull-up resistor must be added. Typically, on a 24 Vdc input a 2.2 K Ohm resistor will be effective.

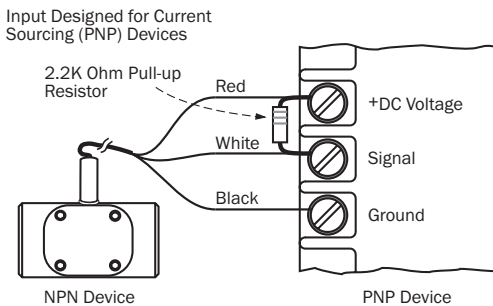

Input designed for current sourcing (PNP) devices

Since the three-wire pickup sensors are solid state, they do not exhibit switch bounce and can be used at relatively high frequencies.

If the PLC is equipped with a 4-20 mA analog input module, it is necessary to order the SES flow sensor with some form of 4-20 mA transmitter. Two options are the AO55 blind transmitter and the FT440 indicating transmitter. Follow the connection diagrams for these products to connect to the analog input.

Rotor Replacement

There is only one moving part to this meter. The bearings are made of ruby, which rarely wears out or needs replacement unless they have been physically damaged by severe shock. The shaft is integrally molded into the rotor, and shaft and rotor are replaced as one part. (You may wish to replace the bearings, using the bearing removal tool, while the meter is disassembled for rotor replacement). To replace the rotor, disconnect the meter and remove the four screws that hold the cover in place. Lift the cover and remove the rotor (see parts diagram below).

When putting in the new rotor, be sure that the ends of the shaft are in both bearings before tightening the cover. The rotor can be easily dropped into the bottom bearing. Starting the shaft into the upper bearing requires a bit of care. It is easier if the rotor is spinning, which can be done by lightly blowing into a port. When the upper bearing plate drops into place, hold it down and check for free spinning (by blowing lightly) before replacing the cover. Check that the O-ring is in its seat on the bearing plate before replacing the cover. Replace the cover, insert the four cap screws and tighten.

Sensor Replacement

The sensor ordinarily does not need replacement unless it is electrically damaged. If replacement is necessary, unscrew the sensor by hand. Screw the replacement sensor in and tighten by hand.



Reconnect the sensor according to the diagram below.

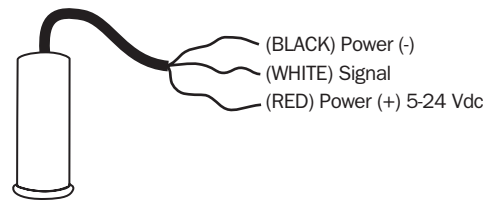

SES Parts List

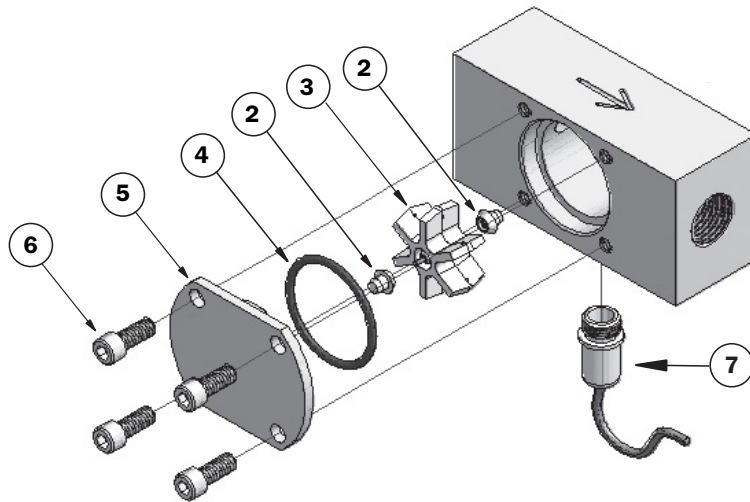

2	Bearing Assembly <i>(Includes 2)</i>	103313
	Bearing Removal Tool <i>(not shown)</i>	100372
3	Rotor with Shaft	
	Kynar®/Ceramic <i>(2 magnet)</i>	103930
	Kynar®/Carbide <i>(2 magnet)</i>	103931
	Kynar®/Silicon Carbide <i>(2 magnet)</i>	103933
	Kynar®/Ceramic <i>(6 magnet, high res)</i>	100453
	Kynar®/Carbide <i>(6 magnet, high res)</i>	103932
Kynar®/Silicon Carbide <i>(6 magnet, high res)</i>	103934	
4	O-Ring*	
	EPDM	100264 (optional)
	Viton®	100219 (optional)
	Teflon®-coated Viton®	100973 (standard)
5	Cover	
	Stainless Steel <i>(SES-050/-075)</i>	100682
	Stainless Steel <i>(SES-100)</i>	100800
6	Hexscrew <i>(4 required)</i>	100693
7	Sensor	
	Standard	100419
	Micropower	100508

Kynar is a registered trademark of Arkema, Inc., Teflon and Viton are registered trademarks for DuPont Corporation

Problem	Probable Cause	Things to Try...
No signal after installation	<p>Insufficient flow</p> <p>Bad connections to control electronics</p> <p>Incompatible control</p> <p>Damaged or missing rotor</p> <p>Failed magnetic sensor</p>	<p>Consult Flow Rate Chart Reduce pipe size or use different sensor</p> <p>Check connections at control: Red (+), Black (-), White (signal)</p> <p>Use 6–36 Vdc power supply - for low power Use 3.1–16 Vdc power supply - for micropowered Add pull up resistor, if using current-sourcing device</p> <p>Remove flow sensor from fitting and check for free spinning; replace rotor</p> <p>Replace magnetic sensor</p>
Inaccurate metering	<p>Not enough straight pipe between meter and severe flow disturbance</p> <p>Wrong K-Factor entered</p> <p>Magnetic sensor failing to pick up each blade</p> <p>Wrong time units on flow indicator</p>	<p>Move meter away from flow disturbance or field calibrate</p> <p>Check fitting for K-Factor, check indicator to see if it is entered properly ("Set K" on FT430, FT440, FT450, or FT520)</p> <p>Remove flow sensor from pipe. If indicator is FT430, FT440, FT450, or FT520, set K to 1.00, turn rotor slowly by hand, indicator should count each blade; replace sensor</p> <p>If using FT430, FT440, or FT520, check left side of display (sec, min, hr, day); change to desired unit</p>

